

Base Mixer Lift

WARNING

Do NOT Cycle lift mechanism unattached from cabinet. PINCH POINTS are present.
LEAVE LIFT MECHANISM IN THE UP POSITION, SECURELY UNTIL MOUNTED IN THE CABINET

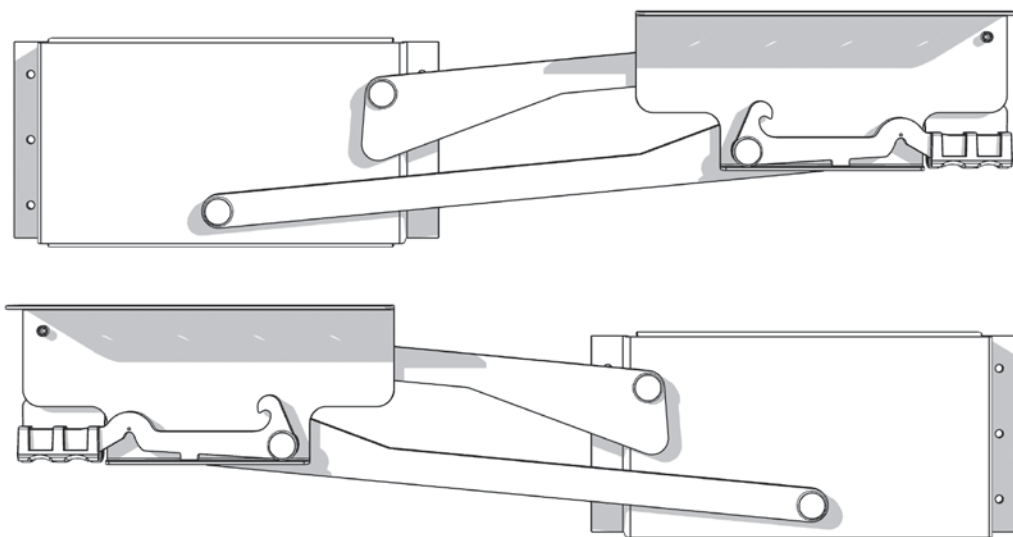

Once installation is complete, remain aware of pinch points
and do not insert hands or body parts in these locations:

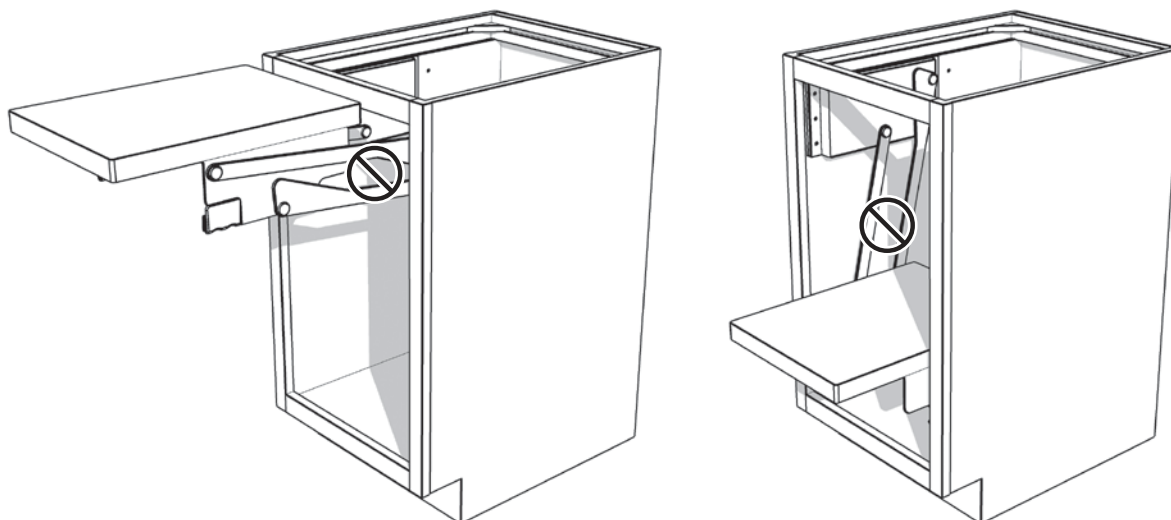

Installation Instructions continued

Read carefully before you begin installation

Base Mixer Lift

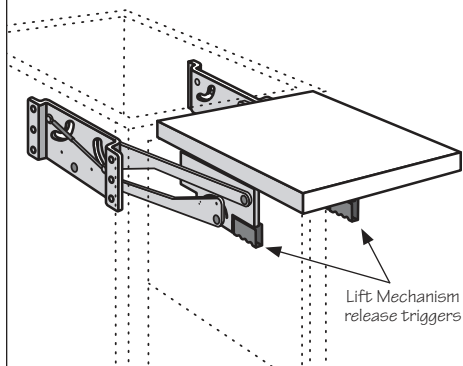

Use this kit to install the Base Mixer Lift Kit.

Fits

For use with B18 FH with Furniture Ends Option.

Contents

- Screw bag containing black and silver screws
- (3) - 1/8" thick spacers
- (2) - Lift mechanisms
- (1) - Butcher Block Top

Tools Needed

- Safety Glasses
- Drill
- Phillips Driver Bit
- Level

Procedure

1 Confirm cabinet has Furniture Ends installed and stack 2 spacers together (Fig. 1A) on the hinge side of the cabinet sliding them flush to the back wall and up so they hit the bottom of the hanging rail (Fig. 1B).

2 Using the 4 Spacer Mounting Holes attach in place with (4) black #8 screws (Fig. 2).

3 Position the remaining spacer in the same location on the opposite (nonhinged) side and attach with (4) black #8x5/8" screws.

4 Identify the left Lift Mechanism and position it over the left spacer aligning it's (6) installation holes with the (6) spacer Lift Mechanism Mounting Holes. Install using (6) silver #8x3/4" screws in the following order (Fig. 3):

- Place a screw in one of the back holes screwing in until flush.
- Ensure the Lift Mechanism is level with the spacer and cabinet and place a screw in the top front hole screwing in until flush.
- Install the remaining 4 screws starting with the remaining back hole locations.

Note: It may be necessary to move the lift mechanism to the lowered position to access all holes on the front. DO NOT MOVE MECHANISM UNLESS IT IS MOUNTED TO CABINET WITH AT LEAST 4 SCREWS.

5 Install the right side Lift Mechanism following the previous process. DO NOT MOVE MECHANISM UNLESS IT IS MOUNTED TO CABINET WITH AT LEAST 4 SCREWS.

6 Cycle both Lift Mechanisms to the up position. Placing the butcher block on the top surface with routed hand grab facing out and down. Attach to Lift Mechanism by screwing (10) black #8x5/8" screws into the pre-drilled holes on the underside of the butcher block top (Fig. 4).

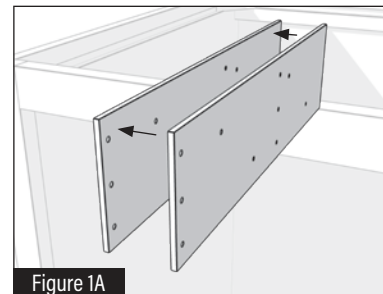

Figure 1A

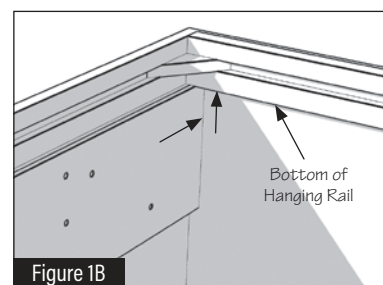

Figure 1B

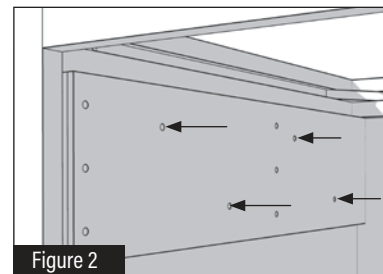

Figure 2

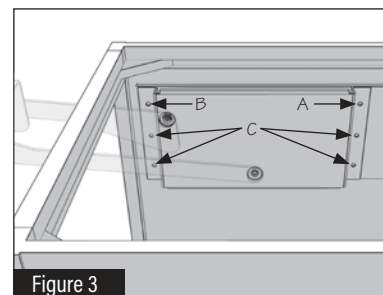

Figure 3

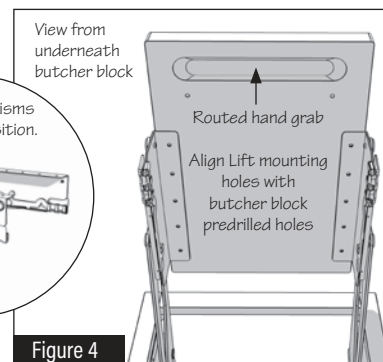
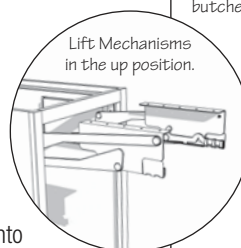

Figure 4



Lift Mechanisms in the up position.